

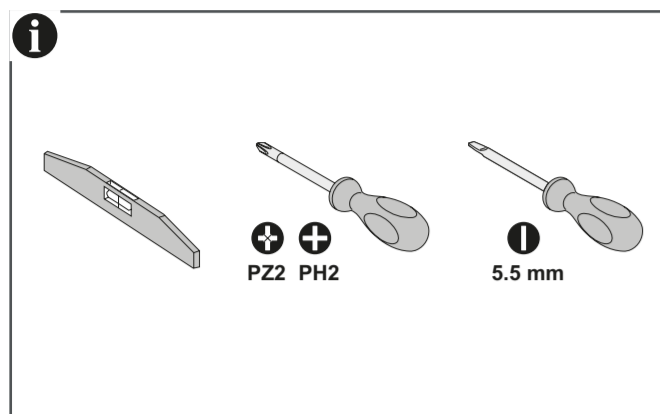

JYT36670

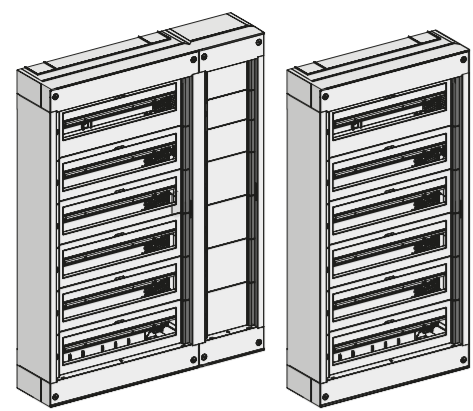

	1	2	2	4	2
24M 4R	1	2	2	4	2
24M 5R	2	3	2	5	3
24M 6R	2	4	2	6	3
24M 7R	2	5	2	7	4
24M 8R	2	6	2	8	4
24M 6R + d	2	0	2	6	3
24M 7R + d	2	0	2	7	4
24M 8R + d	2	0	2	8	4

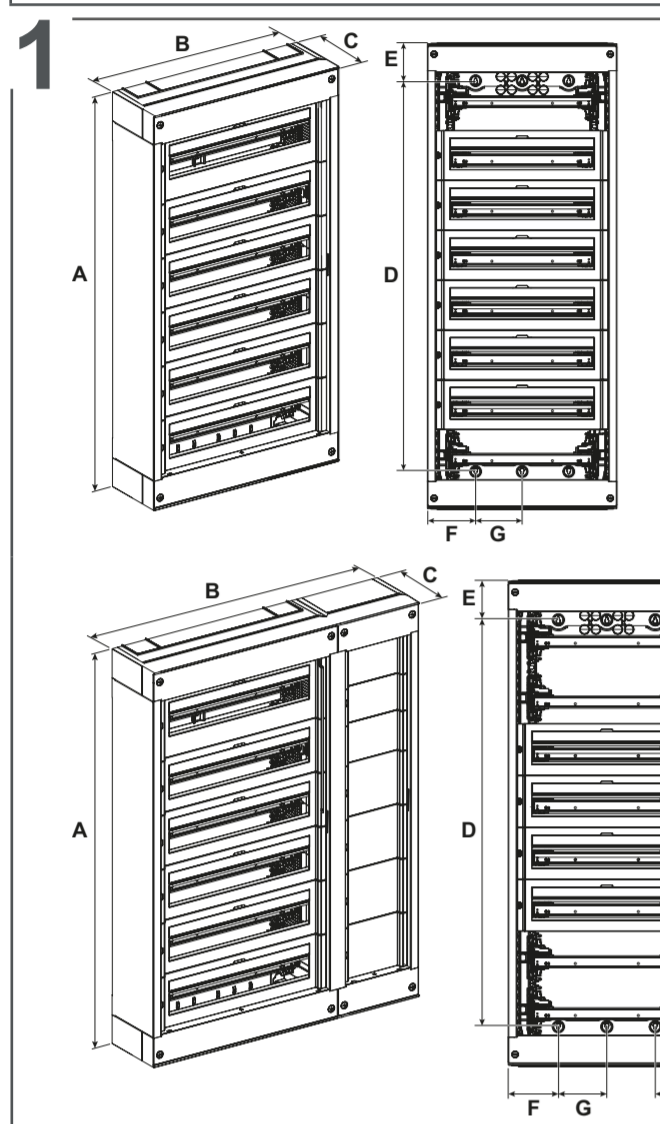

	A (mm)	B (mm)	C (mm)	D (mm)	E (mm)	F (mm)	G (mm)
24M 4R	806	570	191	575.5	106.5	145	140
24M 5R	956			725.5			
24M 6R	1106			875.5			
24M 7R	1256			1025.5			
24M 8R	1406			1175.5			

	A (mm)	B (mm)	C (mm)	D (mm)	E (mm)	F (mm)	G (mm)	H (mm)	I (mm)
24M 6R + d	1106	820	191	875.5	106.5	145	140	270	125
24M 7R + d	1256			1025.5					
24M 8R + d	1406			1175.5					

Schneider Electric

2

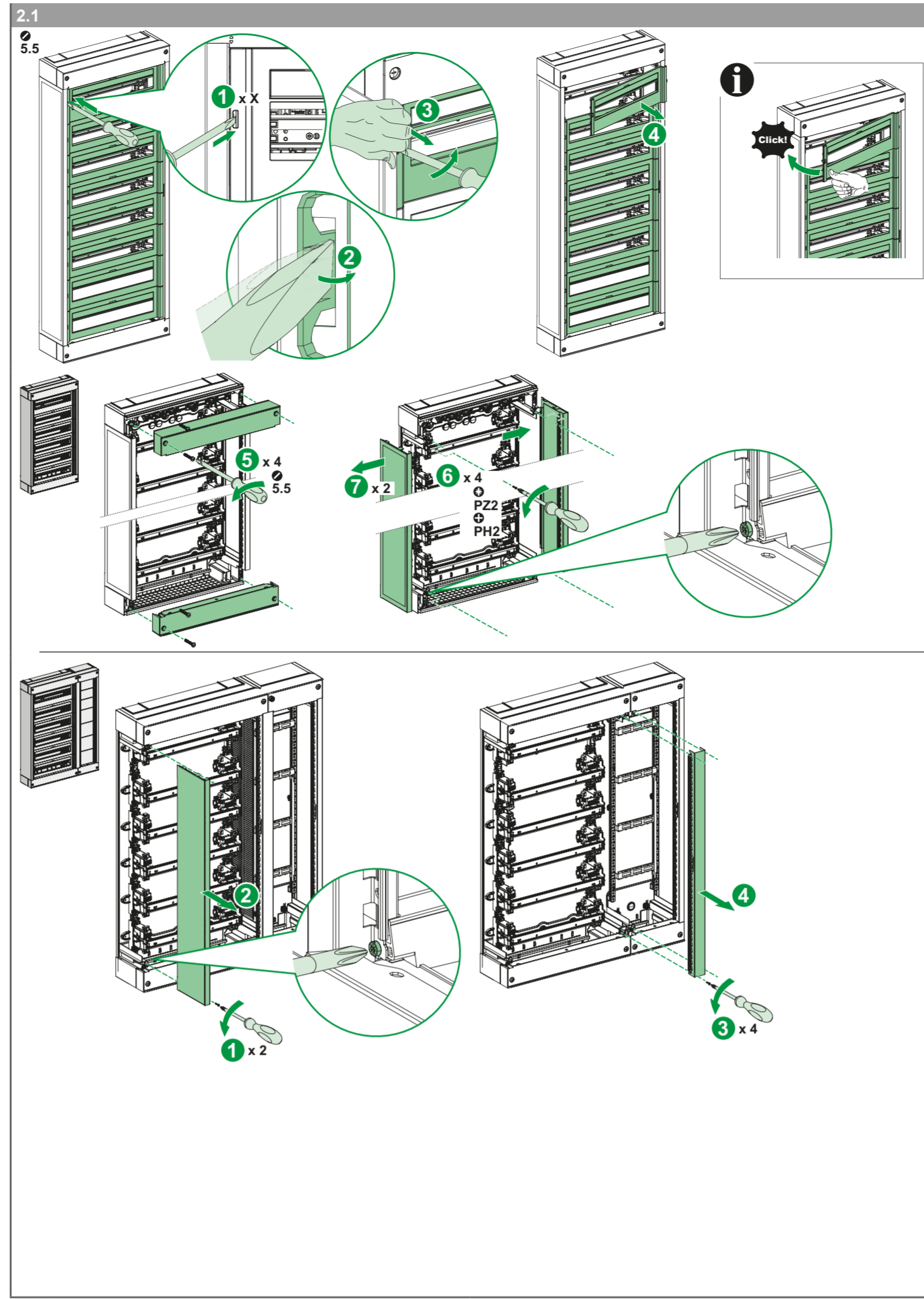

JYT3667001-00

2/12

2

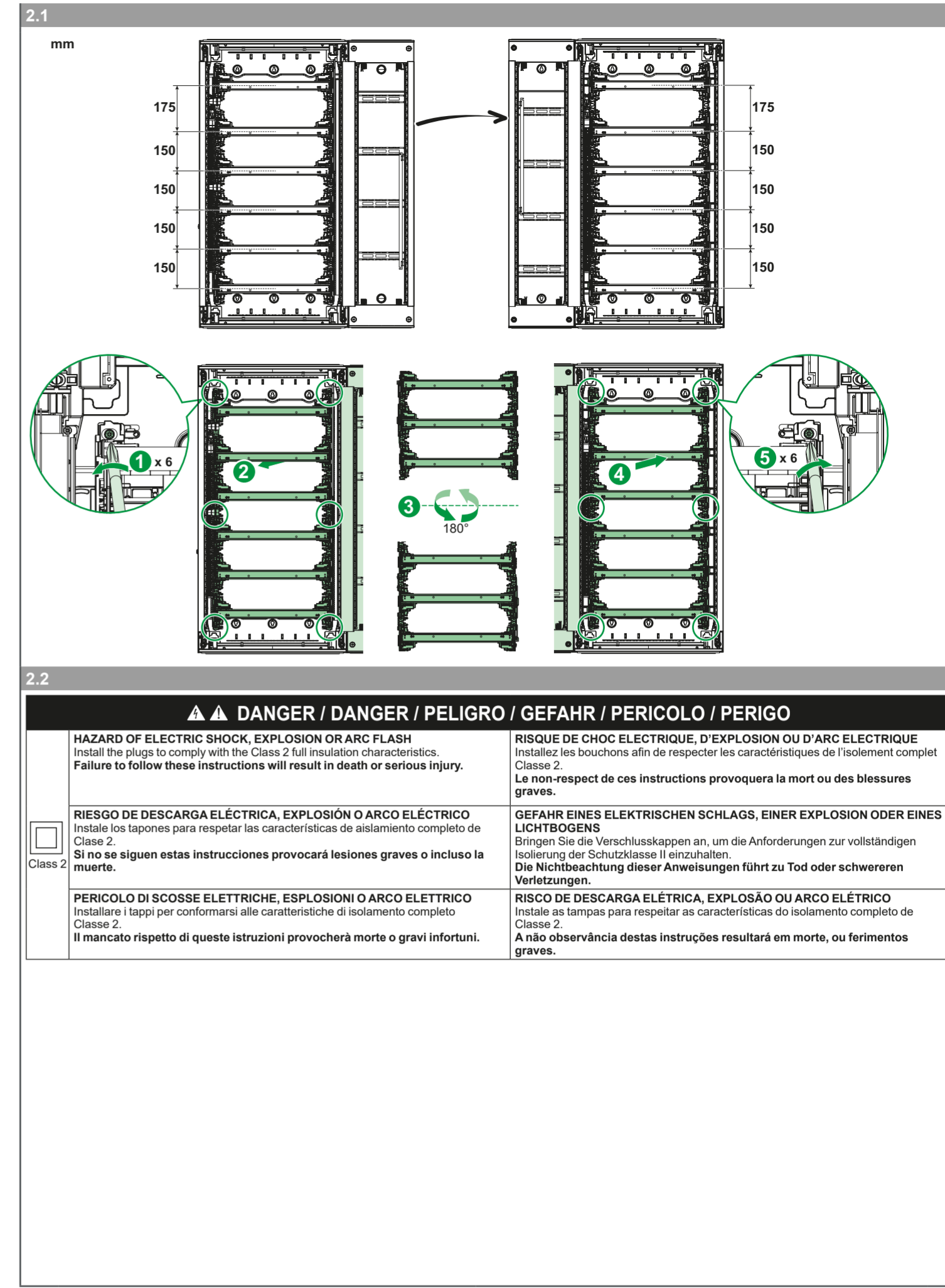

JYT3667001-00

3/12

2

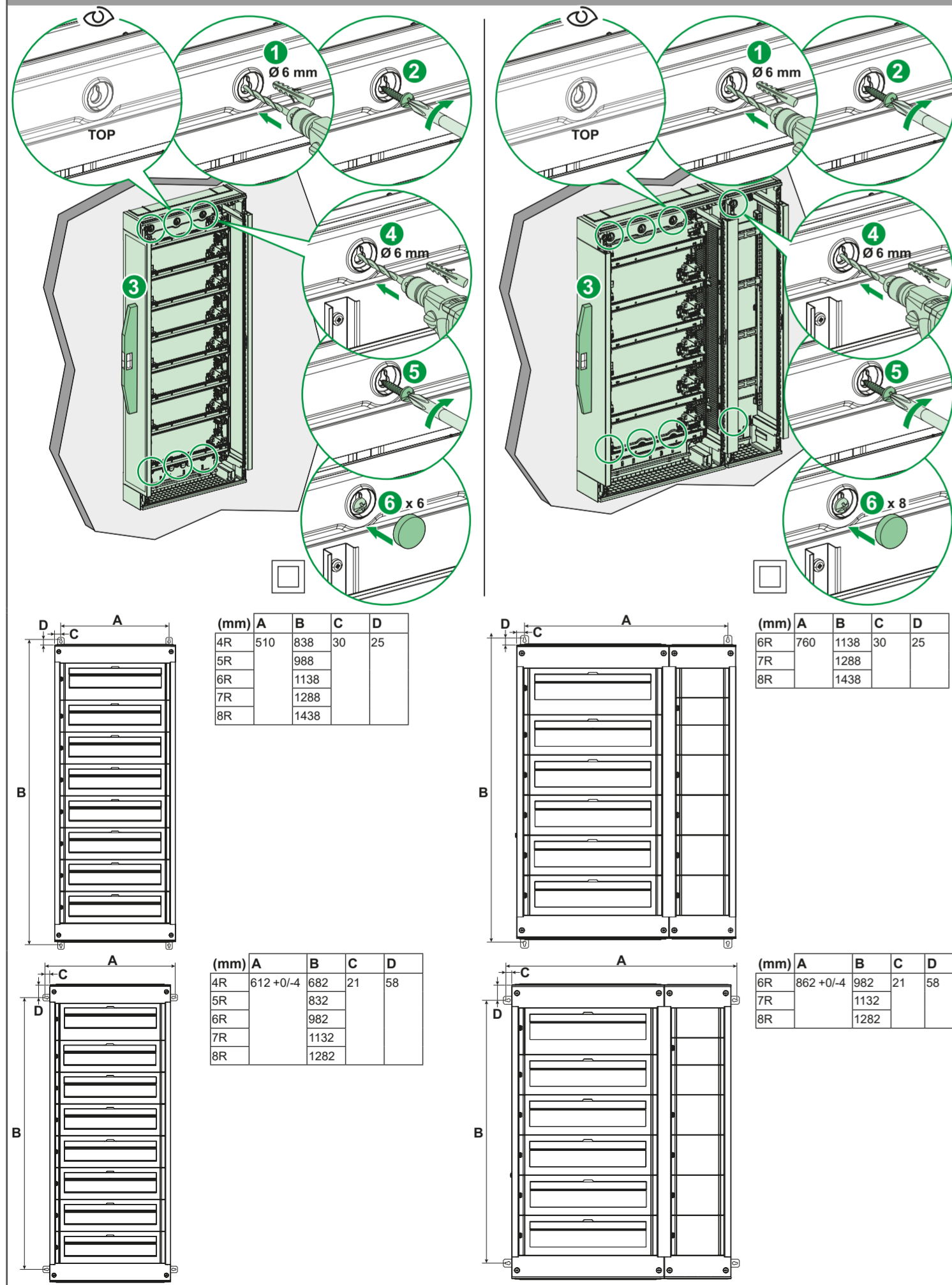

JYT3667001-00

4/12

2

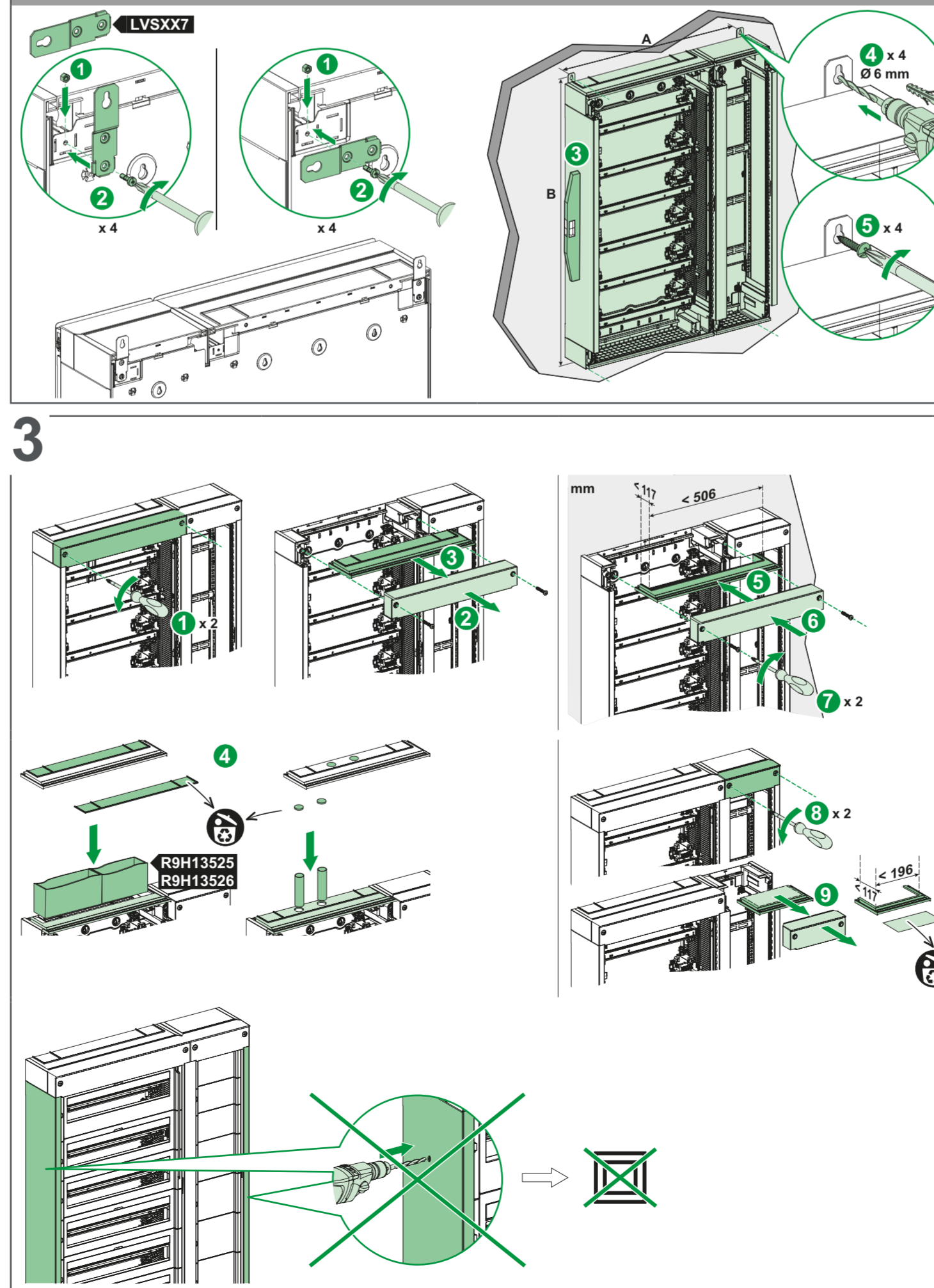

JYT3667001-00

5/12

3

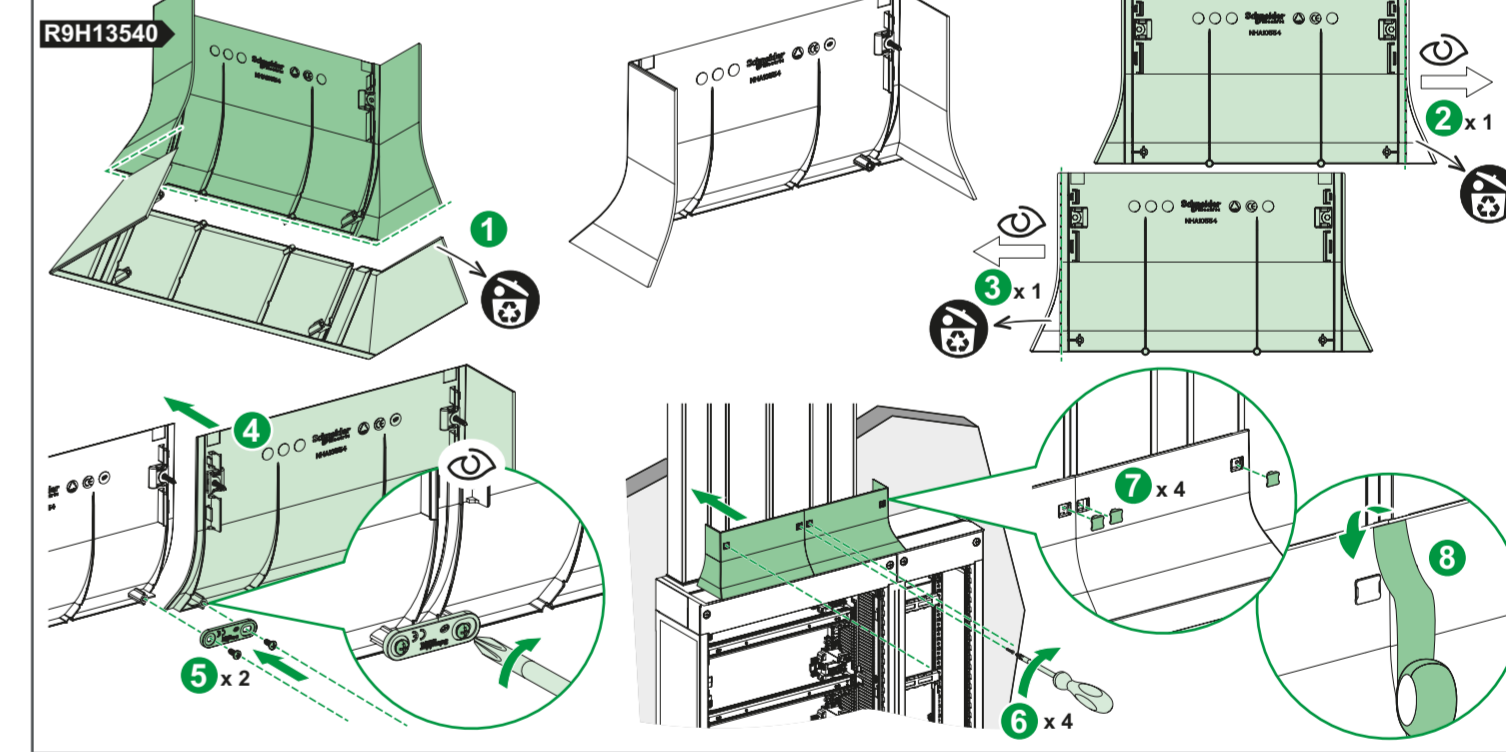

JYT3667001-00

6/12

4

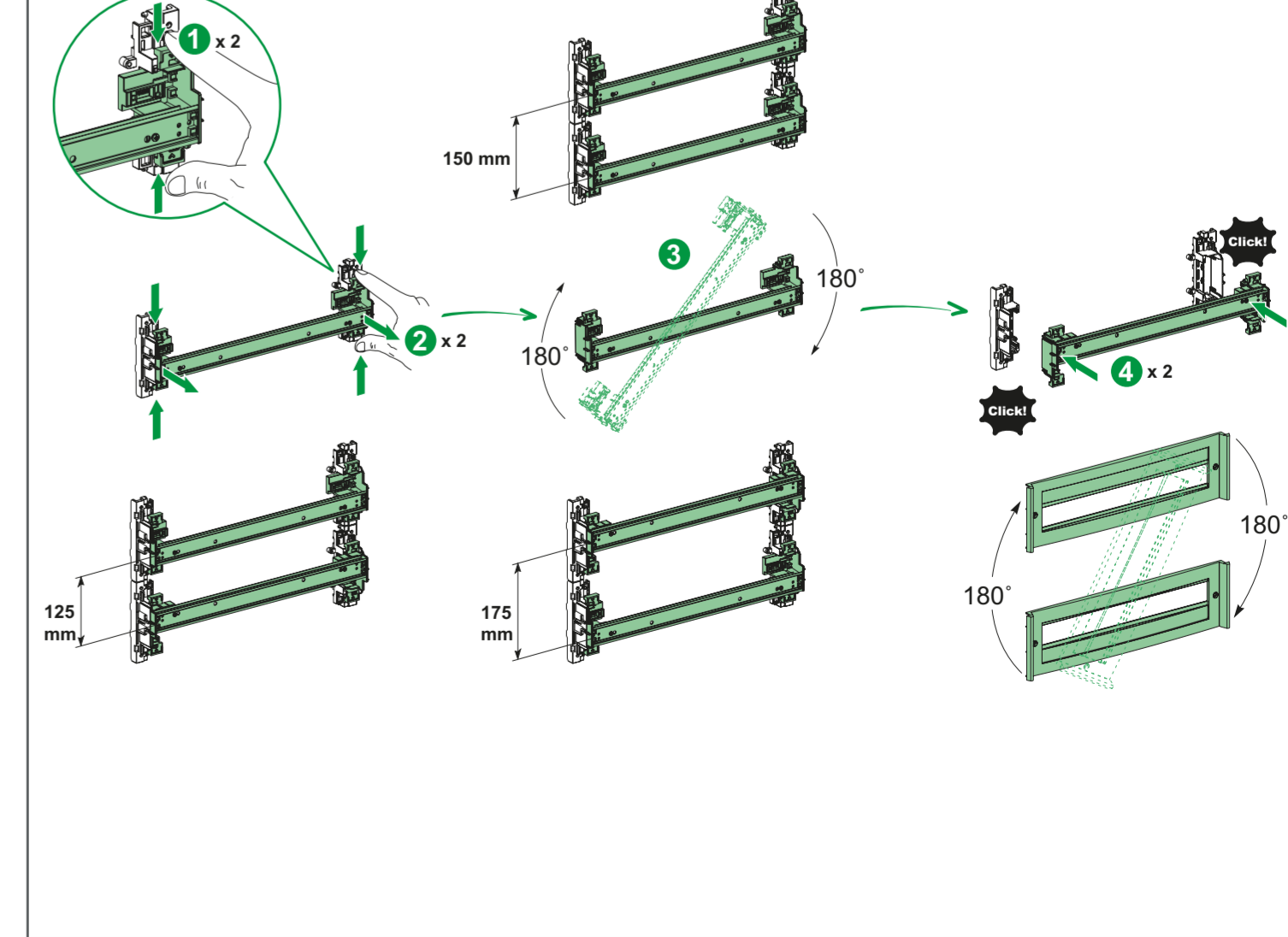

JYT3667001-00

6/12

